



Table of Contents

Introduction	1
Description	1
Calibration	3
Installation	10
Maintenance	13

48^{HR.} DELIVERY



United States/Canada
TOLL FREE
1-800-999-2900

16650 Schoenborn Street
Sepulveda, California 91343, U.S.A.
Tel: (818) 894-7111 • Tlx: 65-1322
FAX: (818) 891-2816
CONNECT (MacNet): MIISEPULVEDA

United Kingdom
FREE PHONE
0800 525107

1 Lloyds Court, Manor Royal, Crawley
W. Sussex RH10-2QU, United Kingdom
Tel: 0293 514488 • Tlx: 87667
FAX: 0293 536852

Australia
TOLL FREE
008 251928

3/18 Resolution Drive, Caringbah
New South Wales 2229, Australia
Tel: (02) 525-9177 • Tlx: 790-75914
FAX: (02) 525-7296

Ask for the STAR Center

Moore Industries' STAR[®] Center has a wide variety of quality instrumentation in stock and ready to ship.

- Signal Transmitters
- Temperature Transmitters
- P/I and I/P Converters
- Isolators and Converters
- Indicators and Displays
- Alarm Trips
- Integrators and Totalizers
- Power Transducers
- Instrument Power Supplies
- Racks, Rails and Enclosures

Most instruments can be customized to meet your needs. Even then, you'll never have to wait more than a few days.

Moore Industries

STAR
CENTER

* Support, Technical Assistance, and Repair (our Quick-Ship Facility)

Introduction

Moore Industries' RBT is an RTD transmitter that converts a 2-, 3-, or 4-wire RTD input to a proportional process current or voltage output.

This manual contains descriptive, calibration, and installation information for the RBT. Notes, Cautions, and Warnings are presented in this manual to help the user avoid minor inconveniences (NOTES), equipment damage (CAUTIONS), and personal injury (WARNINGS) while calibrating or installing this instrument.

Description

The RBT accepts an input from a copper, nickel, or platinum RTD and converts it to a 1-5 mA, 4-20 mA, 10-50 mA, or 1-5 Vdc output. The RBT is powered by either a dc or an ac power source, depending on the unit's housing style. The input type and range, output, and power source requirements are all factory-configured per customer specifications.

The RBT is available in two primary housing styles; the Standard (STD) and Plug-in Card (PC). The STD housing is equipped with a U-back bracket that provides extra protection for the RBT's aluminum housing and allows for mounting on flat sturdy surfaces. The STD unit is also available in several other mounting configurations; each having a different housing code. The PC housing is designed to mount in one of Moore Industries' 19-inch card racks; the RMR or SMR.

Another notable housing style is the EX housing, which is basically a STD unit that has been modified to fit in a high-dome, explosionproof enclosure. On EX units, the electrical connections have been moved from the front of the unit to the bottom. A mating connector is affixed to the base of the explosionproof enclosure for making the electrical connections. The bottom of the RBT housing is fitted with pins that mate with the connector in the base of the enclosure.

Each housing style is designed for a different mounting application, but functionally they are identical.

The housing style you select should be based on the application and the environment in which it is to be used.

Not all features and options are available for all housing styles. For example; while the STD unit can operate from a dc or an ac power source, the PC unit operates on dc power only.

The basic RBT has no visual indicators. It features only two adjustments (ZERO and SPAN), which are located on the front panel of each unit (including EX units). The ZERO adjustment is used to set the zero-percent output of the unit, while the SPAN adjustment is used to set the 100-percent output.

Table 1 contains the performance and operational specifications for the RBT.

Options

The RBT is available with several optional features. The following is a brief description of some of our more popular options:

DT Option – Differential input; the RBT accepts two inputs from 2- or 3-wire RTD's and outputs a process variable that is proportional to the difference in the inputs. (Not available for 4-wire RTD's.)

EZ Option – Elevated Zero input; specifies the input value in ohms that yields a zero-percent output. All RBT's require this option. (Not available for units with DT Option.)

LNP Option – Linearization of the RTD input. (Not available with 5-10 ohm input, or 4-wire RTD's.)

LSA Option – Lower input spans of 0-2 thru 5 ohms, full-scale.

RF Option – RFI/EMI protection; 50 V/m – abc \leq 0.1% of full-scale span as defined by SAMA Standard PMC 33.1. (Not available for all housings.)

For information on availability of other RBT options contact your local Sales Representative or Moore Industries directly.

Table 1. RBT Operational and Performance Specifications

Characteristic	Specification
Input	Factory-configured RTD: 2-, 3-, or 4-wire (Copper, Nickel, or Platinum) Ranges: 0-5 thru 10 Ω 0-80 thru 160 Ω 0-10 thru 20 Ω 0-160 thru 320 Ω 0-20 thru 40 Ω 0-320 thru 630 Ω 0-40 thru 80 Ω (Sensor Current: 1 mA, max; 800 μ A, typical)
Output	Factory-configured 1-5 mA , into 0-4800 Ω 4-20 mA , into 0-1200 Ω 10-50 mA , into 0-480 Ω 1-5 Vdc , into 20 K Ω , minimum (Output limited to 150% of maximum rating.)
Power	Factory-configured 24 Vdc , \pm 10% 45 Vdc , \pm 10% 117, 220 or 240 Vac ; 50/60 Hz; \pm 10% (not for PC units)
Controls	Zero Adjustment: Provides \pm 20% of span adjustability of zero-percent output Span Adjustment: Output fully adjustable over a pre-selected input range <i>With LNP Option:</i> Midscale Adjustment: Adjusts midpoint of input span to improve output linearity <i>For Spans of 320-640Ω:</i> Coarse Zero Adjustment: Used in conjunction with standard zero adjustment for setting the zero-percent output
Performance	Accuracy: \pm 0.1% of span, includes linearity and repeatability Isolation: Input, output, and power terminals are transformer isolated with no dc connections between them; standard for ac and dc powered units Common Mode Rejection: >120 dB @ 60 Hz with a limit of 500 Vrms Ripple: 10 mV P/P @ with maximum load and span Frequency Response: 5 Hz (3 dB point) Load Effect: \pm 0.01% of span from 0 to maximum load resistance Line Voltage Effect: \pm 0.005%/1% line change (ac or dc) Temperature Effect: \pm 0.01%/°C (\pm 0.005%/°F) over ambient operating range
Environmental Ratings	Ambient Operating Temperature: -29 to 82 °C (-20 to 180 °F)
NOTE: Refer to the Installation Section of this manual for unit dimensions.	

Serial/Model Numbers. A historical record is kept at the factory on every product Moore Industries sells and services. This information is keyed to the unit's serial number. If you wish to obtain historical information about a particular product, you must provide the factory with the serial number of the unit.

Moore Industries model numbers identify the unit type, functional characteristics, input and output types, any options, and the units housing type. You should always verify the model number of a unit before placing it into service to ensure it is properly configured for the intended application.

The serial and model numbers for STD units, and units of similar packaging, are edged into a stainless steel tag that is secured to the front of the RBT across the top of the terminal strips. The serial and model numbers for PC units are printed on a label that is affixed to the outer-left side of the front panel. The serial and model number for EX units are located on a label affixed to the top of the unit and on a metal tag on the top of the explosionproof enclosure.

The following example identifies the significance of each field of the RBT model number.

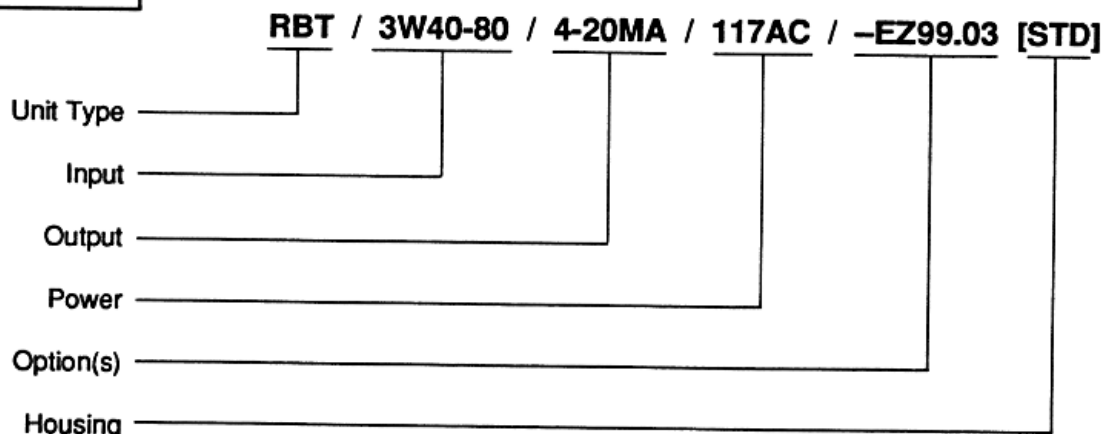
EXAMPLE

Calibration

Every RBT is checked at the factory prior shipment. After receiving your RBT, you should set it up for a bench check and verify that it responds to known inputs in a predictable manner. To do this properly, you must use test equipment to control the input and monitor the output. The bench check will indicate if the RBT is ready to be placed into service, or if it needs to be re-calibrated for your particular application. We recommend you perform a bench check on each unit before placing it into service.

RBT Controls

The basic RBT has two front panel adjustments labeled "ZERO" and "SPAN". Both of these potentiometers (pots) are accessible at the front panel of all housing styles. The ZERO potentiometer adjusts the output for the zero-percent rating of the unit (e.g., 1 mA, 4 mA, 1 Vdc). The SPAN potentiometer adjusts the output for the 100-percent rating of the unit (e.g., 20 mA, 50 mA, 5 Vdc).

RBT

Units With the LNP Option. Units configured with the LNP Option have an additional adjustment labeled "MIDSCALE", which is also accessible at the front panel. This potentiometer adjusts the midpoint setting of the output to provide greater linearity.

Units With Input Spans of 320-640 Ohms. Units with higher input spans of 320 to 640 Ohms have an additional front panel adjustment. This potentiometer is labeled "COARSE ZERO". It is used in conjunction with the basic zero adjustment to set the zero-percent output to the desired level.

All potentiometers on the RBT are equipped with a slip-clutch that prevents them from being damaged should you turn the adjustment beyond the wiper stop. The use of each of these controls is explained in subsequent calibration procedures.

The SC Output Option. Units configured with the SC output option are shipped from the factory with three resistors. Each resistor has a different value and yields a different current output when it is connected across specified terminals of the RBT.

The output current that each resistor will produce is printed on the body of the resistor. Figures 1, 2, and 3 indicate the resistor connections for the SC output option.

Calibration Setup

Since the RBT has no visual indicators, its operational performance can only be verified with calibration equipment. The equipment required to bench check and calibrate the RBT is listed in table 2.

Be sure to use accurately calibrated test equipment to calibrate the RBT. If uncalibrated test equipment is used, the input you apply and output readings you observe will be unreliable and the performance of the RBT unpredictable.

STD-style Units. To set up the STD unit on a shop or laboratory bench for bench check/calibration is relatively easy. The wiring terminals for the STD unit are easy to access since they are all on the front of the unit (see figure 1). But, making connections to the PC and EX units is slightly more involved.

Table 2. RBT Calibration Equipment

Equipment	Characteristic
Decade Resistance Box (See NOTE)	Capable of simulating specified input ranges of the unit being calibrated
DC Power Source (for dc units only)	24 or 45 Vdc, $\pm 10\%$ (as required per unit configuration)
DC Voltmeter	Accuracy of 0.005% or better
Load Resistor	250 Ω for 4-20 mA output; 1000 Ω for 1-5 mA output; 100 Ω for 10-50 mA output; tolerance of 0.001%
Screwdriver	Slotted-tip, head width no greater than 2.54 mm (0.1 inch)
NOTE: Two decade resistance boxes are required to calibrate units with the DT Option.	

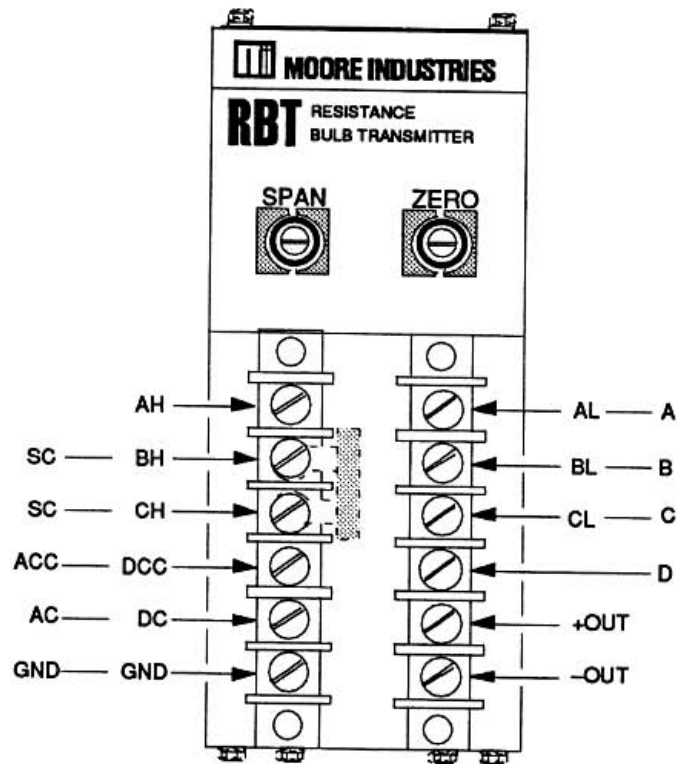

- NOTES:** 1. Check each unit's model number for its power requirements.
 2. For units with the SC output option, verify that the resistor chosen will yield the desired output.

Figure 1. STD Housing Terminal Locations

PC-style Units. The PC unit can be bench checked in its intended rack location by connecting the calibration equipment at the rear terminal strip of the rack. Performing a bench check in the rack can be somewhat cumbersome, but it allows you to verify wiring connections of individual card slots of a card rack.

The PC unit can also be bench checked and calibrated on a bench top using the appropriate mating connector. You can build your own test fixture or special connector for this purpose. However, we

recommend you use Moore Industries' Process Power Supply (PPS) with the CT Option for bench top checks/calibrations of PC units. The PPS (with CT Option) is designed to accept the PC unit and provides terminals for connecting calibration equipment. The terminals on the PPS are numbered in the same manner as the terminals on the rear of a card rack. Connections are made to these terminals as they are to the card rack terminals. The PPS supplies 24 Vdc to the RBT, that would otherwise be connected to the rear terminals of the card rack. Figure 2 identifies the terminal locations for the PC unit.

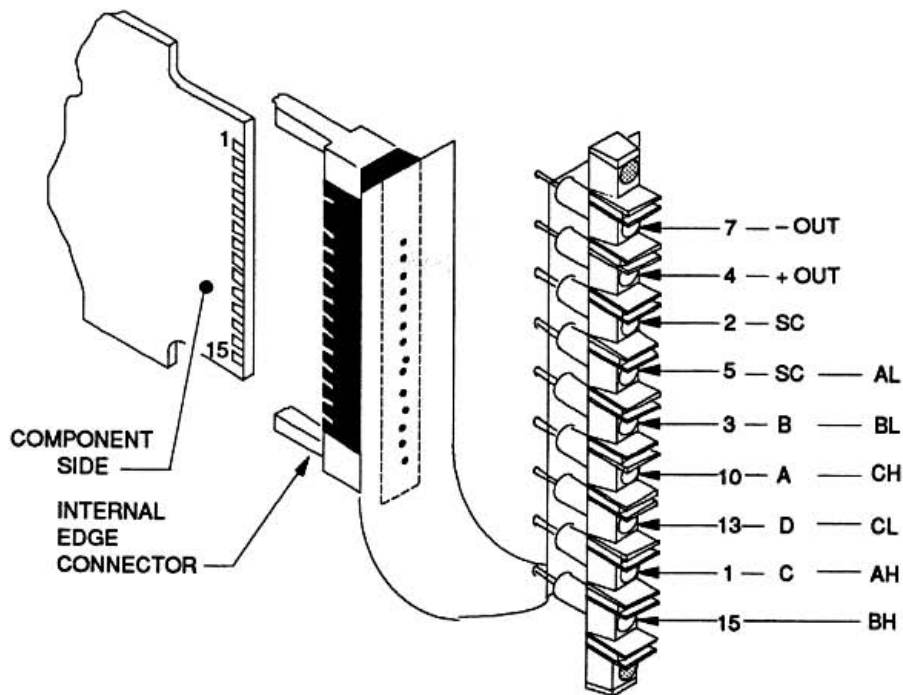

- NOTES:**
1. Check each unit's model number for its dc power requirements.
 2. For units with the SC output option, verify that the resistor chosen will yield the desired output.
 3. DC power is not applied to each rear terminal strip. Power is applied to each PCB internal edge connector at pins 8 (DCC) and 9 (DC).

Figure 2. PC Housing Terminal Locations

EX-style Units. The EX unit includes the explosion-proof enclosure with a terminal block secured to the inside of the base of the enclosure. To wire this unit for bench-top calibration, remove the top of the enclosure and pull the RBT straight out to separate it from the terminal block. Individual terminal screws are used to make electrical connections at each of the terminals (numbered 1 through 12). Figure 3 shows the terminal locations for the EX connector.

Figure 4 is a calibration hookup diagram for the basic RBT. When connecting the calibration equipment to the RBT, be sure to observe the electrical polarities shown in this illustration.

Units With the DT Option. RBT's configured with the DT Option require two independent inputs for bench check or calibration. Two decade resistance boxes are used to calibrate these units, as listed in table 2. Connect the output of one of the resistance boxes to the AL and BL terminals on the RBT. Then, jumper BL to CL. Connect the output of the other resistance box to AH and BH, and jumper BH to CH. Figure 5 is a calibration hookup diagram for units with the DT Option. Refer to the calibration procedure for DT Option units later in this section.

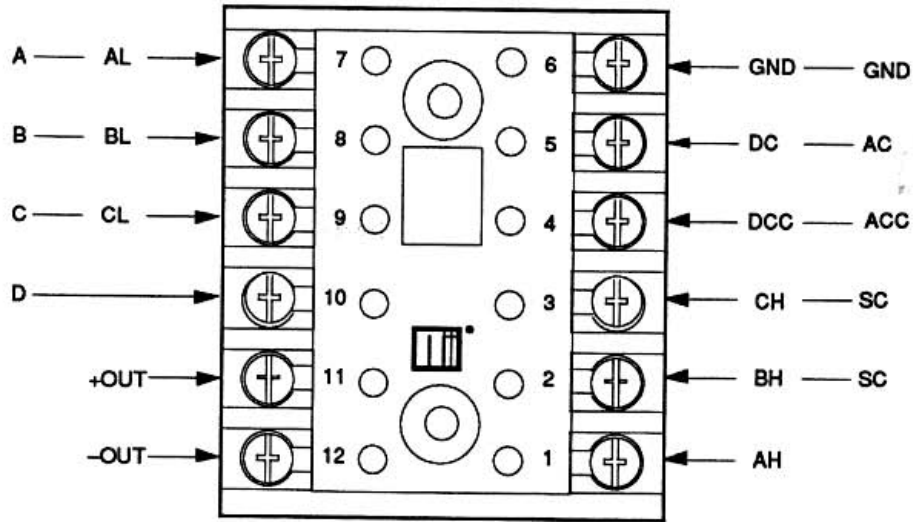

- NOTES:**
1. Check each unit's model number for its power requirements.
 2. For units with the SC output option, verify that the resistor chosen will yield the desired output.

Figure 3. EX Housing Terminal Locations

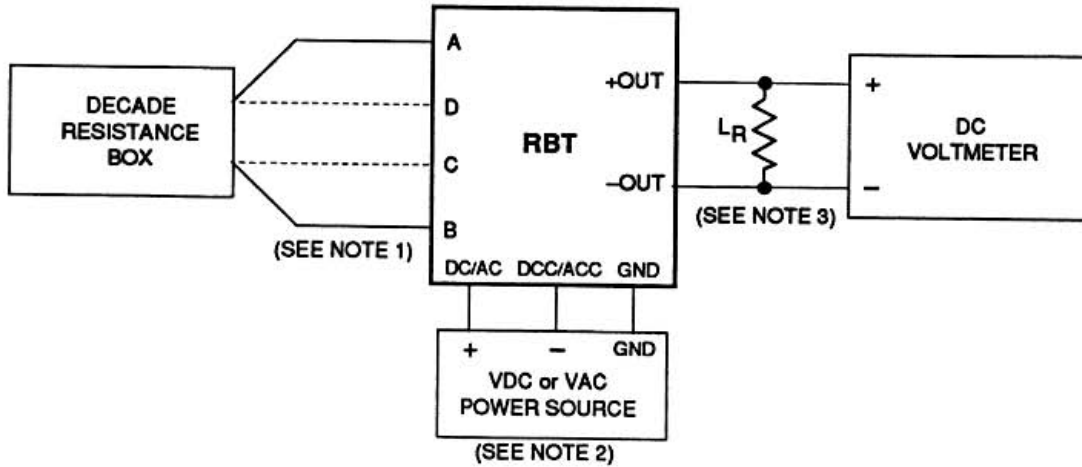

- NOTES:**
1. Terminals A and B are the primary inputs and are used for 2-wire RTD's. Terminals A, B, and C are for 3-wire RTD's. Terminals A, B, C, and D are for 4-wire RTD's.
 2. Check each units model number for its power source requirements.
 3. $L_R = 250\Omega$ for 4-20mA output; 100Ω for 10-50 mA; or 1000Ω for 1-5 mA. Resistor is not needed for voltage output units.

Figure 4. RBT Calibration Hookup

RBT

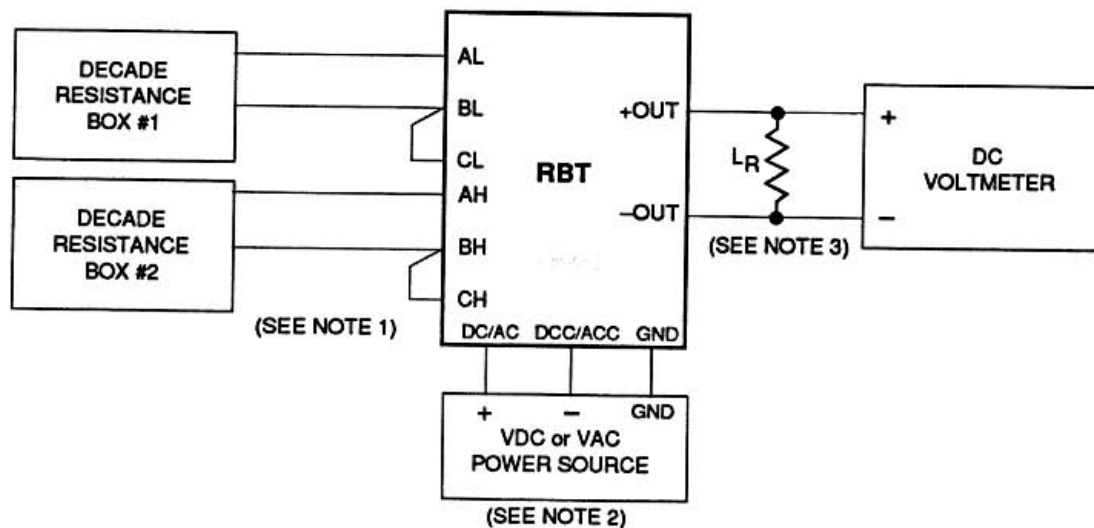

- NOTES:**
1. Terminals A and B are the primary inputs. For calibration, jumper B to C for both sensor inputs (i.e., BL to CL, BH to CH).
 2. Check each unit's model number for its power source requirements.
 3. $L^R = 250\Omega$ for 4-20mA output; 100Ω for 10-50 mA; or 1000Ω for 1-5 mA. Resistor is not needed for voltage output units.

Figure 5. RBT Calibration Hookup for units with the DT Option

Basic Calibration Procedure

The following procedure is intended for RBT's in any housing style. For units configured with the LNP Option, perform this procedure first, then perform the LNP Option Calibration Procedure presented later in this section. For units with the DT Option, go directly to that calibration procedure.

Refer to table 2 for a list of calibration equipment, and set up the RBT using figures 1 through 4, as applicable.

Before proceeding with this calibration procedure, check the model number to verify the power requirements, input span range, and output configurations for your particular unit.

1. Connect RBT and calibration equipment as shown in figure 4.

WARNING

Power terminals are exposed on the STD Housing while the plastic safety cover is removed. To reduce the risk of electrical shock, replace the safety cover after completing wiring connections and before applying power.

2. Apply power and allow RBT to warm up for 5 minutes.
3. Set decade resistance box for minimum input setting appropriate for your application.
4. Monitor output with voltmeter (and load resistor for current output) and adjust ZERO pot to set zero-percent output to required level (e.g., 1 mA, 4 mA, 1 V).
5. Set decade resistance box for maximum input setting appropriate for your application.

6. Monitor output and adjust SPAN pot for 100-percent output to required level (e.g., 5 mA, 20 mA, 5 V).
7. Repeat steps 3 through 6 until no further adjustment of either ZERO or SPAN potentiometer is required.
8. Remove power and disconnect calibration equipment. Basic calibration is complete.

NOTE

For units configured with the LNP Option, refer to the LNP Option Calibration Procedure before disconnecting equipment.

DT Option Calibration Procedure

The DT Option accepts two sensor inputs and produces an output that is proportional to the difference between them. To calibrate units with this option, two input sources are required. In this case, two decade resistance boxes.

Figure 5 shows the calibration hookup required for units with the DT Option. The ZERO and SPAN potentiometers are the only controls used to calibrate units with the DT Option.

Before proceeding with this calibration procedure, check the model number to verify the power requirements, input span ranges, and output configuration for your particular unit. Note the *low* and *high* input span ranges for use later in this procedure.

1. Connect RBT and calibration equipment as shown in figure 5.

WARNING

Power terminals are exposed on the STD Housing while the plastic safety cover is removed. To reduce the risk of electrical shock, replace the safety cover after completing wiring connections and before applying power.

2. Apply power and allow RBT to warm up for 5 minutes.

3. Set both decade resistance boxes to minimum input resistance appropriate for your application.
4. Monitor output with voltmeter (and load resistor for current output) and adjust ZERO pot to set zero-percent output to required level (e.g., 1 mA, 4 mA, 1 V).
5. Set decade resistance box #2 for maximum input resistance appropriate for your application. Leave box #1 at minimum resistance setting.
6. Monitor output and adjust SPAN pot to set 100-percent output to required level (e.g., 5 mA, 20 mA, 5 V).
7. Repeat steps 3 through 6 until no further adjustment of either ZERO or SPAN potentiometer is required.
8. Remove power and disconnect calibration equipment. DT Option calibration procedure is complete.

LNP Option Calibration Procedure

The LNP Option allows you to improve the linearity of the input, which produces a more linear output than would otherwise be achieved.

The LNP Option provides an additional front panel adjustment labeled "MIDSCALE". This adjustment improves the output linearity by 10 fold over non-LNP units.

Before proceeding with this calibration procedure, check the model number to verify the power requirements, input span range, and output configurations for your particular unit.

1. Perform the Basic Calibration Procedure described earlier in this section.
2. Using standard resistance-temperature tables, determine resistance for 25-, 50-, and 75-percent of required input span for your application.

NOTE

The input percentages found must be within the unit's input span range.

RBT

3. Calculate 25-, 50-, and 75-percent of unit's output rating.
4. Set decade resistance box for 50-percent input and adjust MIDSCALE pot for 50-percent output.
5. Apply zero- and 100-percent inputs and readjust ZERO and SPAN pots for zero- and 100-percent outputs as needed.
6. Repeat steps 4 and 5 until no further adjustment is needed for any of the pots.
7. Set decade resistance box for 25- and 75-percent inputs and verify output is at 25- and 75-percent, respectively.
8. If outputs respond properly to corresponding inputs, remove power and disconnect calibration equipment. LNP Option calibration procedure is complete.
9. If outputs do not respond properly, check input and output percentage calculations and perform entire procedure again, starting with the Basic Calibration Procedure.

Installation

Installing the RBT consists of physically mounting the unit and completing the necessary electrical connections. Before placing an RBT into service, you should bench check it to ensure that it is properly configured for its intended application.

The RBT is available in several mounting configurations. The two primary housing styles are the STD and the PC Housings. The long-term performance of the RBT will be greatly enhanced if it is mounted and operated in an area free of excessive dust, moisture, or corrosive elements.

Mounting the RBT

The STD Housing outline dimensions are shown in figure 6. This illustration includes the dimensions for

the U-back bracket. For housing styles similar to the STD, the dimensions shown for the aluminum enclosure alone are the primary dimensions to consider. Different variations of the STD Housing allows for mounting on racks, rails, flat surfaces, and instrument panels. The EX Housing mounts directly inside an explosion-proof enclosure.

Figure 7 is an outline dimension drawing of the PC Housing. This housing style is designed specifically for mounting in one of Moore Industries' 19-inch instrument racks (RMR or SMR). These card racks are either rack-mounted (RMR) or surface-mounted (SMR).

Making the Electrical Connections

Electrical connections to STD and EX units are made to individually marked terminals. Table 3 lists the terminal assignments for STD and EX units. (See figures 1 and 3 in the Calibration Section for specific terminal locations.) STD-type units are powered by either an ac or a dc power source. The power requirement for each unit is contained in its model number.

PC units slide into card slots in Moore Industries' 19-inch card racks. Each unit has individual contacts on its rear edge that mate with an edge connector at the inside rear of the rack. Internally, each connector is connected to individual terminal strips that are accessed at the external, rear panel. The numbering adjacent to each terminal strip corresponds to the edge connector contacts for each PC unit. Power is supplied to each unit via the power connections to the rack and internal bussing.

PC units operate on dc power ONLY, which is specified in each unit's model number. DC power is not present at the rear panel terminal strips. Table 4 lists the terminal assignments for the PC unit. See figure 2 in the Calibration Section for specific terminal locations.

Figure 8 is an installation hookup diagram for the RBT.

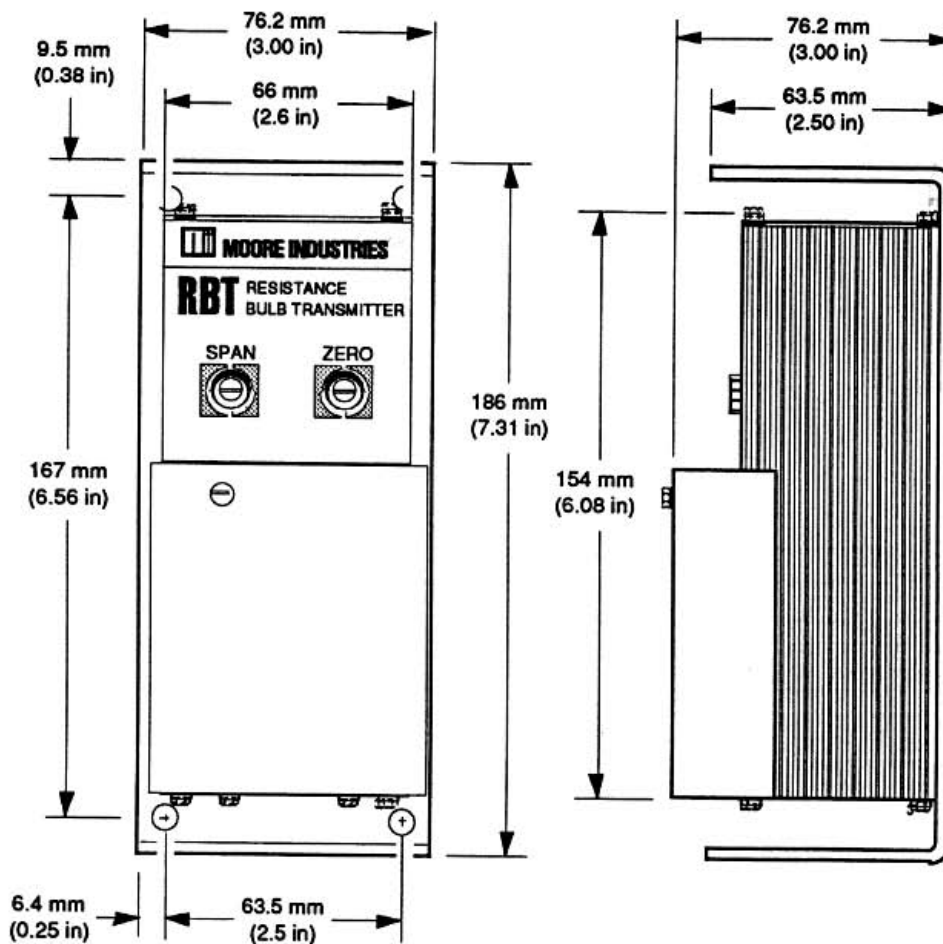

Figure 6. RBT, STD Housing Outline Dimensions

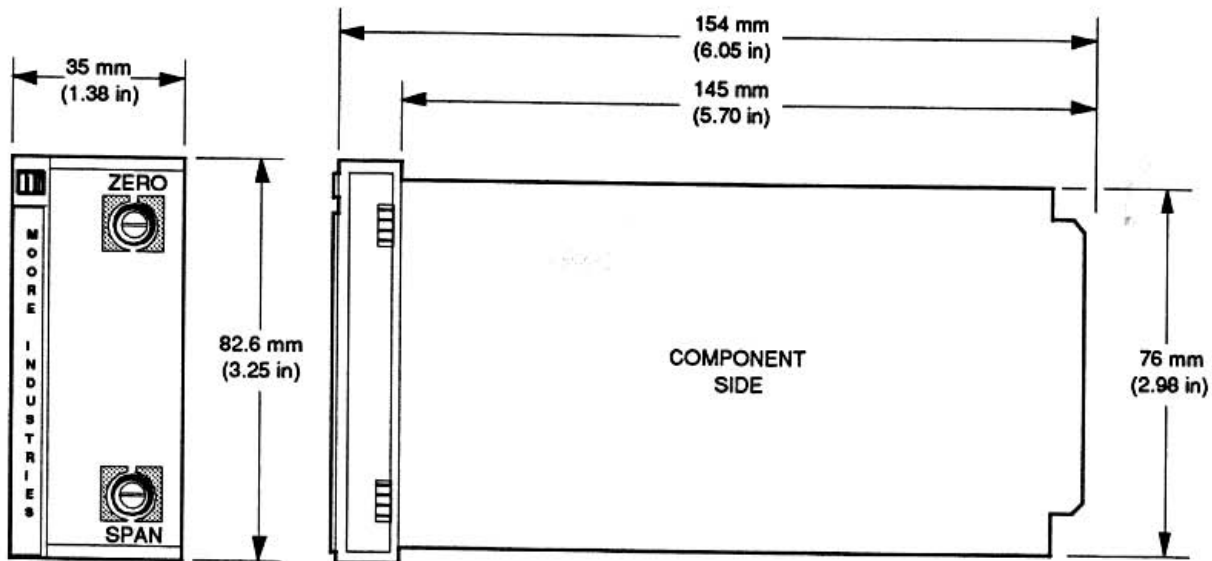

Figure 7. RBT, PC Housing Outline Dimensions

Table 3. RBT STD and EX Housing Terminal Designations

Options	Terminals											
	1	2	3	4	5	6	7	8	9	10	11	12
Basic DC Powered				DCC	DC	GND	A	B	C	D	+OUT	-OUT
Basic AC Powered				ACC	AC	GND	A	B	C	D	+OUT	-OUT
Unit with SC Output		SC	SC	(See NOTE)	(See NOTE)	(See NOTE)	A	B	C	D	+OUT	-OUT
Unit with DT Option	AH	BH	CH	(See NOTE)	(See NOTE)	(See NOTE)	AL	BL	CL		+OUT	-OUT

NOTES: 1. Check each unit's model number for its power requirements.
 2. Terminals A and B are the primary inputs. Terminals A,B, and C are used for 3-wire RTD's. Terminals A through D are used for 4-wire RTD's.

LEGEND: AC, AC power input
 ACC, AC power return
 GND, Chassis ground
 SC, Selectable Current (output)
 DC, DC power input (+)
 DCC, DC power return (-)

+OUT, Positive current or voltage output
 -OUT, Negative current or voltage output
 A, B, C, D, RTD sensor inputs
 AL, BL, CL, Low sensor input
 AH, BH, CH, High sensor input

Table 4. RBT PC Housing Terminal Designations

Options	Terminals (at rear of card rack)								
	7	4	2	5	3	10	13	1	15
DC Powered PC Unit	-OUT	+OUT			B	A	D	C	
Unit with SC Output	-OUT	+OUT	SC	SC	B	A	D	C	
Unit with DT Option	-OUT	+OUT		AL	BL	CH	CL	AH	BH
NOTES: 1. DC power is bussed to pins 8 and 9 of each internal card connector of the rack, but is not present at the rear terminals. 2. Terminals A and B are the primary inputs. Terminals A, B, and C are used for 3-wire RTD's. Terminals A through D are used for 4-wire RTD's.									

LEGEND: SC, Selectable Current (output)
 +OUT, Positive current or voltage output
 -OUT, Negative current or voltage output

A, B, C, D, RTD sensor inputs
 AL, BL, CL, Low sensor input
 AH, BH, CH, High sensor input

Maintenance

Once the RBT is properly calibrated and installed, it will operate reliably for extended periods of time. Routine maintenance of the RBT is limited to keeping the unit clean and ensuring terminal connections are secure and free of oxidation. We recommend that you visually inspect the unit at least once every six months to ensure its physical condition is acceptable.

Periodically, you may wish to check the performance of the RBT to ensure that it is operating within the desired parameters. To check its operational performance, take the unit off-line and set it up for a bench check by using the calibration equipment and hookup information contained in the Calibration Section of this manual. Apply a known input to the

RBT and monitor its output for a predictable result. If the output is out of tolerance or at an unacceptable level, perform the calibration procedures.

The schedule for in-service bench checks depends on your facility's maintenance practices and on indications of need. We recommend that you bench check the RBT approximately once a year. But, if there is no indication of variation in performance, you may elect to let the RBT remain on-line for longer periods.

If an operational problem arises with the RBT, contact Moore Industries' Customer Service Department at 1-800-999-2900 or your local Sales Representative. To return a unit, follow the instructions on the back cover of this manual.

RBT

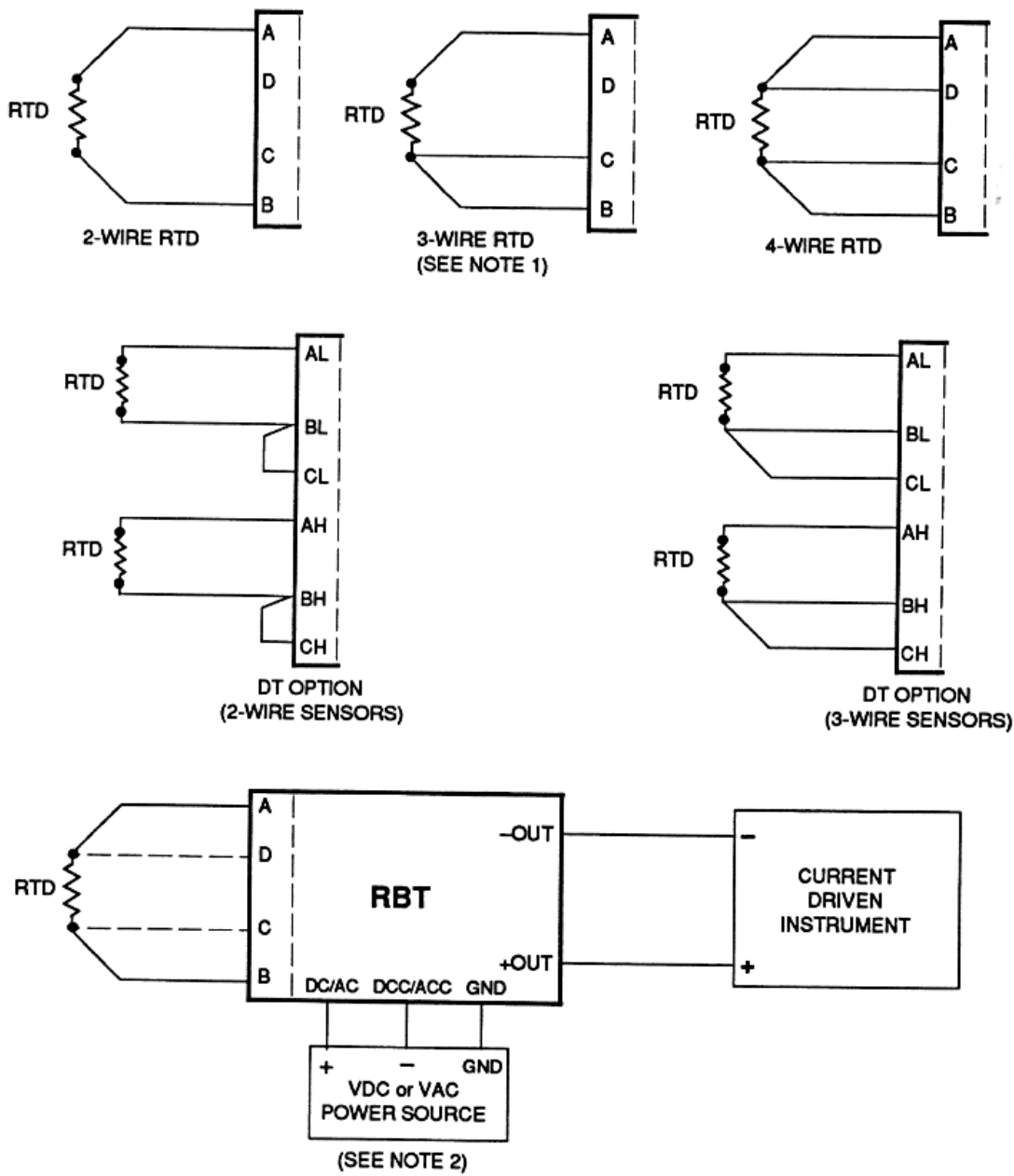

- NOTE:** 1. For 3-wire RTD's and dual sensors with lead length compensation, all leads should be of the same gauge and length, and kept at the same temperature.
 2. Check the unit's model number for its power requirements.

Figure 8. RBT Installation Hookup

RETURN PROCEDURES

To return equipment to Moore Industries for repair, follow these four steps:

1. Call Moore Industries and request a Returned Material Authorization (RMA) number.

Warranty Repair –

If you are unsure if your unit is still under warranty, we can use the unit's serial number to verify the warranty status for you over the phone. Be sure to include the RMA number on all documentation.

Non-Warranty Repair –

If your unit is out of warranty, be prepared to give us a Purchase Order number when you call. In most cases, we will be able to quote you the repair costs at that time. The repair price you are quoted will be a "Not To Exceed" price, which means that the actual repair costs may be less than the quote. Be sure to include the RMA number on all documentation.

2. Provide us with the following documentation:
 - a) A note listing the symptoms that indicate the unit needs repair
 - b) Complete shipping information for return of the equipment after repair
 - c) The name and phone number of the person to contact if questions arise at the factory
3. Use sufficient packing material and carefully pack the equipment in a sturdy shipping container.
4. Ship the equipment to the Moore Industries location nearest you.

The returned equipment will be inspected and tested at the factory. A Moore Industries representative will contact the person designated on your documentation if more information is needed. The repaired equipment, or its replacement, will be returned to you in accordance with the shipping instructions furnished in your documentation.

WARRANTY DISCLAIMER

THE COMPANY MAKES NO EXPRESS, IMPLIED OR STATUTORY WARRANTIES (INCLUDING ANY WARRANTY OF MERCHANTABILITY OR OF FITNESS FOR A PARTICULAR PURPOSE) WITH RESPECT TO ANY GOODS OR SERVICES SOLD BY THE COMPANY. THE COMPANY DISCLAIMS ALL WARRANTIES ARISING FROM ANY COURSE OF DEALING OR TRADE USAGE, AND ANY BUYER OF GOODS OR SERVICES FROM THE COMPANY ACKNOWLEDGES THAT THERE ARE NO WARRANTIES IMPLIED BY CUSTOM OR USAGE IN THE TRADE OF THE BUYER AND OF THE COMPANY, AND THAT ANY PRIOR DEALINGS OF THE BUYER WITH THE COMPANY DO NOT IMPLY THAT THE COMPANY WARRANTS THE GOODS OR SERVICES IN ANY WAY.

ANY BUYER OF GOODS OR SERVICES FROM THE COMPANY AGREES WITH THE COMPANY THAT THE SOLE AND EXCLUSIVE REMEDIES FOR BREACH OF ANY WARRANTY CONCERNING THE GOODS OR SERVICES SHALL BE FOR THE COMPANY, AT ITS OPTION, TO REPAIR OR REPLACE THE GOODS OR SERVICES OR REFUND THE PURCHASE PRICE. THE COMPANY SHALL IN NO EVENT BE LIABLE FOR ANY CONSEQUENTIAL OR INCIDENTAL DAMAGES EVEN IF THE COMPANY FAILS IN ANY ATTEMPT TO REMEDY DEFECTS IN THE GOODS OR SERVICES, BUT IN SUCH CASE THE BUYER SHALL BE ENTITLED TO NO MORE THAN A REFUND OF ALL MONIES PAID TO THE COMPANY BY THE BUYER FOR PURCHASE OF THE GOODS OR SERVICES.

ANY CAUSE OF ACTION FOR BREACH OF ANY WARRANTY BY THE COMPANY SHALL BE BARRED UNLESS THE COMPANY RECEIVES FROM THE BUYER A WRITTEN NOTICE OF THE ALLEGED DEFECT OR BREACH WITHIN TEN DAYS FROM THE EARLIEST DATE ON WHICH THE BUYER COULD REASONABLY HAVE DISCOVERED THE ALLEGED DEFECT OR BREACH, AND NO ACTION FOR THE BREACH OF ANY WARRANTY SHALL BE COMMENCED BY THE BUYER ANY LATER THAN TWELVE MONTHS FROM THE EARLIEST DATE ON WHICH THE BUYER COULD REASONABLY HAVE DISCOVERED THE ALLEGED DEFECT OR BREACH.

RETURN POLICY

For a period of thirty-six (36) months from the date of shipment, and under normal conditions of use and service, Moore Industries ("The Company") will at its option replace, repair or refund the purchase price for any of its manufactured products found, upon return to the Company (transportation charges prepaid and otherwise in accordance with the return procedures established by The Company), to be defective in material or workmanship. This policy extends to the original Buyer only and not to Buyer's customers or the users of Buyer's products, unless Buyer is an engineering contractor in which case the policy shall extend to Buyer's immediate customer only. This policy shall not apply if the product has been subject to alteration, misuse, accident, neglect or improper application, installation, or operation. THE COMPANY SHALL IN NO EVENT BE LIABLE FOR ANY INCIDENTAL OR CONSEQUENTIAL DAMAGES.



WORLDWIDE • www.miinet.com

United States • info@miinet.com Tel: (818) 894-7111 • FAX: (818) 891-2816	Belgium • info@mooreind.be Tel: 03/448.10.18 • FAX: 03/440.17.97	China • sales@mooreind.sh.cn Tel: 86-21-62491499 • FAX: 86-21-62490635
Australia • sales@mooreind.com.au Tel: (02) 8536-7200 • FAX: (02) 9525-7296	The Netherlands • sales@mooreind.nl Tel: (0)344-617971 • FAX: (0)344-615920	United Kingdom • sales@mooreind.com Tel: 01293 514488 • FAX: 01293 536852